



**Action Requested/Required:**

- Vote/Action Requested
  - Discussion or Presentation Only
  - Public Hearing
- Report Date: 4/29/26  
Hearing Date: \_\_\_\_\_  
Voting Date: 5/21/26

**Department:** Community Development      **Presenter(s) & Title:** Tyler Peoples  
City Planner

**Agenda Item Title:**

Discussion and Possible Action on Request for Master Signage Plan at Canton Overlook located at 205 Hospital Road

**Summary:**

The applicant has submitted a Master Sign Plan for the townhome development currently under construction on the Mary Lane Extension. The property is zoned PD-MU and thus eligible for Master Sign Plan approval. The Applicant is requesting design approval of two monument signs with one at each development entrance.

**Budget Implications:**

Budgeted?  Yes  No  N/A  
Total Cost of Project:  Check if Estimated   
Fund Source: General Fund  Water & Sewer  Sales Tax  Other:

**Staff Recommendations:**

Staff recommends approval of this application.

**Reviews:**

Has this been reviewed by Management and Legal Counsel, if required?  Yes  No

**Attachments:**

LOI  
Site Plan  
Elevations and Sections



built with care.

**Letter of intent- Entrance monuments for Canton Overlook**

Eastwood Homes of Georgia, LLC  
1000 Mansell Exchange West  
Building 350  
Alpharetta, GA 30022  
Phone: 248.494.1044

Dear Sir or Madam,

This Letter of Intent is submitted for review and consideration by the City of Canton regarding the proposed installation of neighborhood entrance monuments for the residential community known as **Canton Overlook**, located at **205 Hospital Road**.

The intent of this project is to install **decorative entrance monuments** that clearly identify the Canton Overlook neighborhood, enhance the aesthetic character of the community entrance, and align with the City of Canton’s development standards and design guidelines. The monuments are intended to be purely aesthetic and wayfinding in nature, with no advertising, lighting impacts beyond code allowances, or obstruction to sight distance or public infrastructure.

**Project Description**

- **Monument Type:** Permanent masonry/stone entrance monuments
- **Purpose:** Neighborhood identification and visual enhancement
- **Location:** At the primary entrance(s) to Canton Overlook along Mary Lane
- **Construction Materials:** Concrete, Block, Stone and Brick
- **Height & Setbacks:** To comply with all applicable City of Canton zoning and sign regulations

All improvements will be constructed in accordance with approved plans, applicable City ordinances, and any conditions imposed by the City of Canton. No encroachments into public right-of-way will occur unless expressly permitted and approved by the City.

**Maintenance**

The entrance monuments will be **privately owned and maintained** by the property owner and/or the Canton Overlook homeowners’ association. The City of Canton shall bear no responsibility for ongoing maintenance, repair, or replacement of the monuments.

**Compliance**

Final construction drawings, monument details, and placement will be submitted as required for permitting and review. The project team understands that all work is subject to City inspection and approval prior to and upon completion.

We respectfully request the City of Canton’s review and approval of this intent in order to proceed with the necessary permitting and installation of the entrance monuments. Should you require additional information or clarification, please do not hesitate to contact me.

Thank you for your time and consideration.

Sincerely,

**Wyatt McGrath**

**Land Development Manager**

**Eastwood Homes**

**Phone: (770) 815-2338**

**Email: [Wmcgrath@eastwoodhomes.com](mailto:Wmcgrath@eastwoodhomes.com)**

# Canton Overlook

## Monument Construction Documents

### CANTON, GEORGIA

ISSUED: APRIL 7, 2026

VICINITY MAP

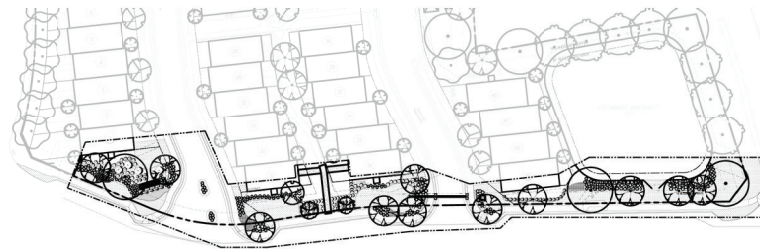

#### SHEET INDEX

SHEET	DESCRIPTION
--	COVER
L-1	Sign Monument Details
L-2	Column Monument Details
L-3	Landscape Plan
L-4	Landscape Details
L-5	Landscape Notes

#### OWNER / 24 HOUR CONTACT

WYATT MCGRATH  
EASTWOOD HOMES  
TEL: 770.815.2338

IF YOU DIG GEORGIA...  
CALL US FIRST!



LANDSCAPE ARCHITECT  
CHAU WALL AND ASSOCIATES, LLC  
285 WEST WIEUCA ROAD, NE #5303  
ATLANTA, GEORGIA 30342  
TEL: (404) 456-7071  
WWW.CHAUWALLASSOCIATES.COM  
CWALL@CHAUWALLASSOCIATES.COM











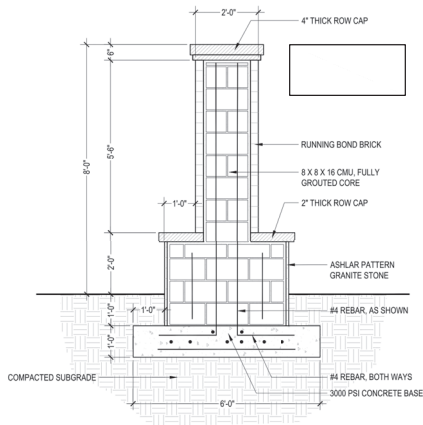

04 Sign Monument Column-Section  
L-1 SCALE: 1/2" = 1'-0"

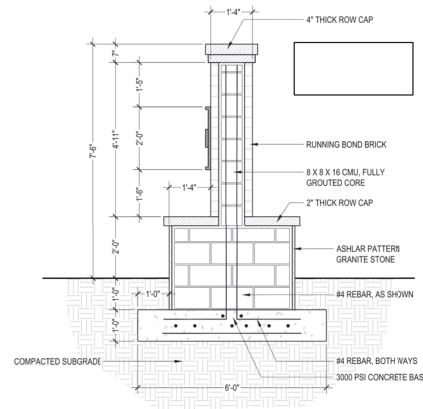

05 Sign Monument Wall-Section  
L-1 SCALE: 1/2" = 1'-0"

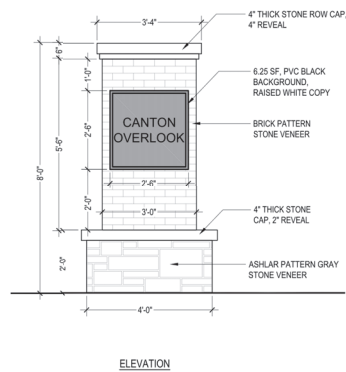

ELEVATION

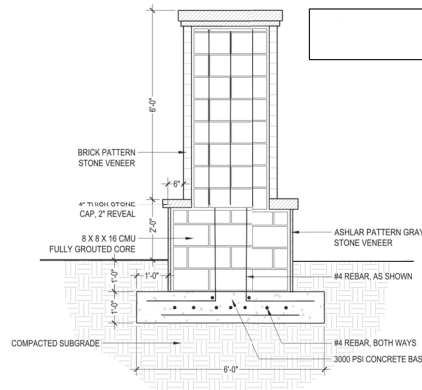

COLUMN SECTION

03 Sign Monument-Enlargement  
L-2 SCALE: 1/2" = 1'-0"

**FAIRBANKS**  
ENGINEERING  
COMPANY, LLC

Phone: 404-787-8266  
Fax: 404-995-4459  
5825 Glenridge Drive  
Building 4, Suite 104  
Atlanta, GA 30328

Canton Overlook  
Subdivision  
Eastwood Homes  
City of Canton, Cherokee County, GA



DRAWN: MJK  
DATE: 4/22/2026  
SCALE: N.T.S.  
PROJ. NO.:  
SHEET NO.:

**MILLROSE**  
PROPERTIES

501 Office Center Drive, Suite 350  
Fort Washington, PA 19034  
(215) 653-8884

MRP HEWB, LLC  
205 Hospital Road  
Canton, GA

April 24, 2026

City of Canton  
Planning & Zoning Department  
110 Academy Street  
Canton, GA 30114

Re: Property Owner Authorization – Entrance Monument  
Canton Overlook Development  
103 Dogwood Alley, Canton, GA

Dear Sir or Madam,

MRP HEWB, LLC is the fee simple owner of the property located at 205 Hospital Road, Canton, Georgia. This letter serves as formal notification and authorization to the City of Canton regarding the construction of an entrance monument within the Canton Overlook development, located at 103 Dogwood Alley, Canton, Georgia.

As the property owner, MRP HEWB, LLC consents to and authorizes the construction, installation, and use of the proposed entrance monuments as part of the approved development plans for Canton Overlook. This improvement is intended to support the residents of the development and will be constructed in accordance with all applicable City of Canton ordinances, development regulations, and approved plans.

The undersigned is the duly authorized signatory for MRP HEWB, LLC and is authorized to execute this authorization on behalf of the ownership entity.

Should you require any additional information, documentation, or clarification, please do not hesitate to contact me.

Sincerely,



Ed Hadley  
Authorized Signatory  
MRP HEWB, LLC

**MILLROSE**  
PROPERTIES

501 Office Center Drive, Suite 350  
Fort Washington, PA 19034  
(215) 653-8884

MRP HEWB, LLC  
205 Hospital Road  
Canton, GA

April 24, 2026

City of Canton  
Planning & Zoning Department  
110 Academy Street  
Canton, GA 30114

Re: Property Owner Authorization – Entrance Monument  
Canton Overlook Development  
201 Oakwood Bend, Canton, GA

Dear Sir or Madam,

MRP HEWB, LLC is the fee simple owner of the property located at 205 Hospital Road, Canton, Georgia. This letter serves as formal notification and authorization to the City of Canton regarding the construction of an entrance monument within the Canton Overlook development, located at 201 Oakwood Bend, Canton, Georgia.

As the property owner, MRP HEWB, LLC consents to and authorizes the construction, installation, and use of the proposed entrance monuments as part of the approved development plans for Canton Overlook. This improvement is intended to support the residents of the development and will be constructed in accordance with all applicable City of Canton ordinances, development regulations, and approved plans.

The undersigned is the duly authorized signatory for MRP HEWB, LLC and is authorized to execute this authorization on behalf of the ownership entity.

Should you require any additional information, documentation, or clarification, please do not hesitate to contact me.

Sincerely,



Ed Hadley  
Authorized Signatory  
MRP HEWB, LLC